

# Installation Instructions

## Webasto eBTM 2.0

## Stand-alone Battery Thermal Management



## English

### Installation Instructions for:

eBTM 2.0 400 V

eBTM 2.0 800 V

## Table of Contents

<b>1</b>	<b>About this document</b> .....	<b>4</b>
1.1	Purpose of this document.....	4
1.2	Using this document.....	4
1.3	Use of symbols and highlighting .....	4
1.4	Warranty and liability.....	4
<b>2</b>	<b>Important safety information</b> .....	<b>4</b>
2.1	General information .....	4
2.2	Qualifications of installation personnel.....	4
<b>3</b>	<b>System description</b> .....	<b>4</b>
<b>4</b>	<b>Acronyms and abbreviations</b> .....	<b>5</b>
<b>5</b>	<b>Technical data ratings</b> .....	<b>5</b>
5.1	Technical data .....	5
5.2	Centre of Gravity .....	5
<b>6</b>	<b>Operating modes</b> .....	<b>6</b>
<b>7</b>	<b>External interfaces</b> .....	<b>6</b>
<b>8</b>	<b>Installation procedure</b> .....	<b>8</b>
8.1	Installation Recommendations .....	8
8.2	Planning the installation .....	8
8.3	Installation Instructions.....	9
8.4	Filling circuits.....	10
<b>9</b>	<b>System activation</b> .....	<b>13</b>

## eBTM 2.0 Validities

The Installation instructions is valid for:

Description	Kit Part Number	Unit Part Number
eBTM 2.0 400V without refrigerant	6247243A	6247244
eBTM 2.0 400V with refrigerant	6247703A	6247899
eBTM 2.0 800V without refrigerant	6247710A	6247476
eBTM 2.0 800V with refrigerant	6247477A	6247901

Table 1: eBTM 2.0 Validities

# 1 About this document

## 1.1 Purpose of this document

This document is an integral part of the product and contains the information required to ensure correct and safe installation and operation.

## 1.2 Using this document

- ▶ Read these Installation Instructions (II) carefully before installing the unit.

## 1.3 Use of symbols and highlighting

This document uses warning labels and colours for hazard classification in accordance with ISO 3864: See also <https://www.iso.org/standard/55814.html>.

	<b>DANGER</b> This signal word denotes a hazard with a <b>high</b> degree of risk which, if not avoided, may lead to death or serious injury.
	<b>WARNING</b> This signal word denotes a hazard with a moderate degree of risk which, if not avoided, may lead to minor or moderate injury.
	<b>CAUTION</b> This signal word denotes a hazard with a <b>low</b> degree of risk which, if not avoided, may lead to minor or moderate injury.
	<b>NOTE</b> This symbol denotes a special technical feature, or (if not observed) potential damage to the product.
	This symbol refers to separate documents which may be enclosed or can be requested from Webasto.

✓	Requirements for the following necessary action
▶	Necessary action

## 1.4 Warranty and liability

Webasto shall not assume liability for defects or damages that are the result of disregarding the installation and operating instructions. This liability exclusion particularly applies to:

- Improper use.
- Use of non-genuine parts.
- Conversion of the unit without permission from Webasto.
- Mechanical damage to the equipment.
- Non-compliance with inspection and maintenance instructions.

# 2 Important safety information

	<b>CAUTION</b> Read, and comply with the warnings in the Installation Instructions and Service Instructions.
	<b>NOTE</b> Only use genuine Webasto parts.

## 2.1 General information

The device must only be used in a technically faultless condition. Any malfunctions that adversely affect the safety of persons or of the device must be immediately rectified by a qualified electrician in accordance with nationally applicable regulations.

## 2.2 Qualifications of installation personnel

The installation personnel must have the following qualifications:

- Successful completion of Webasto training
- Corresponding qualification for working on technical systems

# 3 System description

With the eBTM 2.0, Webasto offers a compact system that is capable of handling the battery pack's thermal management of large vehicles, such as busses, trucks and light commercial vehicles (vehicle classes include: M2, M3, N1, N2, and N3 as described in Regulation (EU) 2018/858. See also <https://eur-lex.europa.eu/legal-content/EN/TXT/?uri=CELEX%3A32018R0858>.

Active battery thermal management ensures that the liquid cooled battery packs function in an optimal way, and has been designed in accordance with the requirements of various applications and customers.

The eBTM 2.0 aims to provide a fluid flow with a given target temperature and fixed flow rate. The fluid consists of a mixture of water and glycol. The coolant outlet temperature range is between 0 °C and 70 °C. The fluid flow rate delivered by the system depends on the total pressure losses in the circuit which is connected to the eBTM 2.0. The system can regulate the coolant outlet temperature to a fixed target through a refrigerant circuit (in cooling mode), or to an electrical heater (in heating mode).

The minimum and maximum temperature depends on the system design and operating modes, and on the flow rate and temperature of the inlet fluid. The coolant inlet temperature depends on the customer's system configuration, and on the fluid flow users external to the system. The heating and cooling capacity of the eBTM 2.0 are defined by the coolant flow on the eBTM 2.0 interface times its temperature difference. The performance of the eBTM 2.0 is affected by the layout of the connected coolant system and the environmental conditions. The eBTM 2.0 environmental air temperature operating range is between -35 °C and +50 °C.

The eBTM 2.0 system needs the following in all the operating modes:

- electrical power to be supplied by an external user at different voltage levels (HVPS, LVES).
- activation and control signals by an external CAN communication bus (CAN 2.0 or J1939).

The eBTM 2.0 system provides feedback signals about the operating modes and the status of the internal components (see \*.DBC file). You can calculate the outlet flow rate by crossing the characteristic curve of the eBTM 2.0, dashed line in Fig. 11, with the pressure drop curve of the external circuit. The outlet flow rate is reported in chapter 8.2.2, "Battery Circuit Design" on page 8.

## 4 Acronyms and abbreviations

Abbr.	Description
BEV	Battery Electric Vehicle
BMS	Battery Management System
CAN (bus)	Controller Area Network (bus)
CFEX	Evaporator (Cold Fluid Heat Exchanger)
CG	Centre of Gravity
COP	Coefficient of Performance (also: CP)
DC	Direct Current
eBTM	Electric Battery Thermal Management
ECU	Electronic Control Unit
ESS	Battery (Energy Storage System)
EXT-ACT	External Activation
ExtCoLoop	External Coolant Loop
EXV	Electronic eXpansion Valve
GWP	Global Warming Potential
HEX	Radiator (External Air Heat Exchanger)
HFEK	Condenser (Hot Fluid Heat Exchanger)
HP	High Pressure
HPS	High-Power Supply
HPS-	High-Power Supply Terminal -
HPS+	High-Power Supply Terminal +
HV	High Voltage
HVH	High-Voltage Heater
HVPS	High-Voltage Power Supply
IntCoLoop	Internal Coolant Loop
LIN (bus)	Local Interconnect Network (bus)
LP	Low Pressure
LV	Low Voltage
LVES	Low-Voltage Electronic Supply
LVPS	Low-Voltage Power Supply
VIB	Vehicle Interface Box
VIG	Vehicle Interface Gateway

Table 2: Used abbreviations

## 5 Technical data ratings

### 5.1 Technical data

Technical specifications	eBTM 2.0 400 V <sub>DC</sub>	eBTM 2.0 800 V <sub>DC</sub>
Max. Cooling capacity	8 kW <sup>(1)</sup>	8 kW <sup>(1)</sup>
Max. Heating capacity	7 kW	10 kW
Max. Power consumption @HV	7.5 kW (heating) / 6 kW (cooling)	10.5 kW (heating) / 6 kW (cooling)
Refrigerant	R-1234yf	R-1234yf
Refrigerant Charge [g]	500	500
Battery Coolant	Water/Ethylene Glycol mix at 50-50%	Water/Ethylene Glycol mix at 50-50%
Internal Circuit Coolant Quantity [l]	3	3
External Circuit Coolant Quantity (eBTM side) [l]	3.4 + 0.75 <sup>(2)</sup>	3.4 + 0.75 <sup>(2)</sup>
Nominal coolant volume flow	52 l/min @ dP 0.5 barA <sup>(3)</sup>	54 l/min @ dP 0.5 barA <sup>(3)</sup>

Technical specifications	eBTM 2.0 400 V <sub>DC</sub>	eBTM 2.0 800 V <sub>DC</sub>
Nominal HV supply [V <sub>DC</sub> ]	365	675
HV operating range [V <sub>DC</sub> ]	300 - 432	500 - 850
HV overvoltage limit [V <sub>DC</sub> ]	450	865
Communication with VIB	CAN BUS 2.0 B / CAN J 1939 Baudrate 500 kbps <sup>(4)</sup>	CAN BUS 2.0 B / CAN J 1939 Baudrate 500 kbps <sup>(4)</sup>
Nominal Low-Voltage supply (LVES)	12 or 24 (not simultaneously) <sup>(5)</sup>	12 or 24 (not simultaneously) <sup>(5)</sup>
LV operating range	9...16 @ 12 or 18...32 @ 24	9...16 @ 12 or 18...32 @ 24
DC-Link Capacity (Cx)	55 µF	67 µF
Max. voltage rise [V/ms]	40	40
Cy - Capacity	70 nF	70 nF
Min Isolation Resistance (@ 1000 V <sub>DC</sub> )	500 kOhm	500 kOhm
Max. discharge time (HV < 60 V <sub>DC</sub> )	3 s (@ 432 V <sub>DC</sub> )	45 s (@ 850 V <sub>DC</sub> )
Max. Voltage withstand [V <sub>AC</sub> ]	1900 V <sub>AC</sub> for 1 min	1900 V <sub>AC</sub> for 1 min
Discharge time according to ISO 6469-3 (max.)	17 seconds	17 seconds
Operational ambient temperature range [°C]	-35 ... +50	-35 ... +50
Storage temperature range [°C]	-40 ... +70	-40 ... +70
Set Point temperature range at the outlet [°C]	0 ... +70	0 ... +70
Protection IP degree	IP66	IP66
Compressor	Scroll (High-voltage electric)	Scroll (High-voltage electric)
Dimensions L x W x H [mm]	1000 <sup>(6)</sup> x 700 x 300	1000 <sup>(6)</sup> x 700 x 300
Weight [kg]	<91 kg	<91 kg
Electric pre-charging internal HV components	NOT included	NOT included
Sound Pressure Level LpA [dB(A)] <sup>(7)</sup>	76.5 dB(A)	78.5 dB(A)
<sup>(1)</sup> T <sub>external air</sub> = 35 °C, T <sub>set Point</sub> = 25 °C, the set point temperature is the coolant temperature requested from the system.		
<sup>(2)</sup> The eBTM 2.0 portion of the external circuit is 3.4 l. An extra 0.75 l must be considered for filling the extra reservoir connected to the external circuit.		
<sup>(3)</sup> See chapter 8.2.2, "Battery Circuit Design" on page 8		
<sup>(4)</sup> Baudrate 250 kbps also available.		
<sup>(5)</sup> 60 W max power consumption for signal @12/24 V during eBTM 2.0 operation.		
<sup>(6)</sup> This dimension does not include the presence of the fixing brackets. The fixing brackets measure 50 mm each and can be installed on the longitudinal or the lateral sides.		
<sup>(7)</sup> Sound pressure level of a work-cycle of the eBTM 2.0 at 70% power in 1 m distance.		

Table 3: Technical data

### 5.2 Centre of Gravity

Fig. 1 shows the position of the Centre of Gravity (CG).

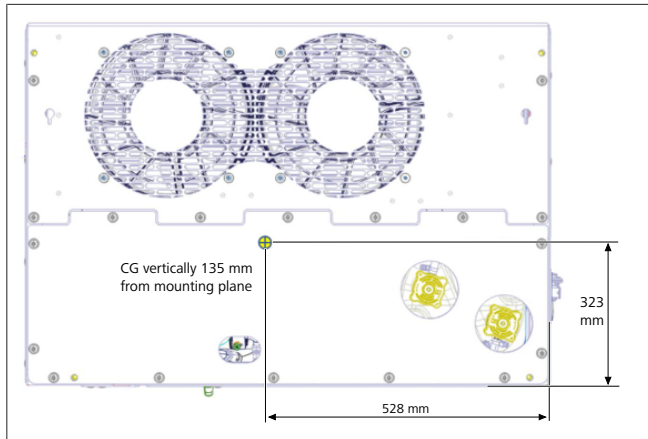

Fig. 1 eBTM 2.0 CG in x-y plane

## 6 Operating modes

The eBTM 2.0 system functionalities are based on the heat transfer between two thermal sources at different temperatures, realized by a cooling unit installed inside the eBTM 2.0 system and based on a closed refrigerant cycle system with refrigerant/coolant heat exchangers such as evaporator and condenser (this is Webasto Heat Pump 80). In the evaporator (CFEX) the refrigerant removes heat from the coolant providing the cold coolant flow. In the condenser (HFEX) the refrigerant provides heat to the coolant providing the hot coolant flow.

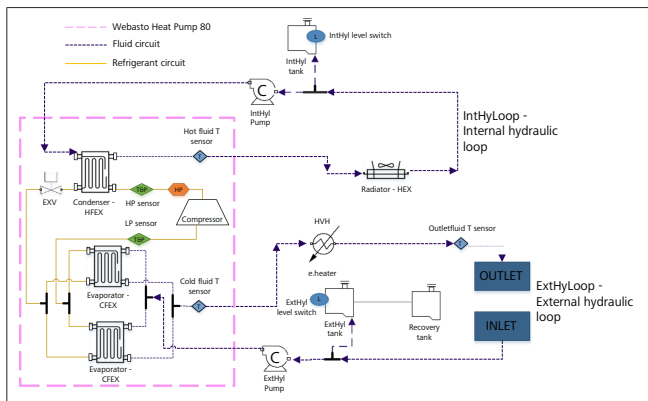

Fig. 2 eBTM 2.0 circuits

The two different coolant loops are made independent by two different coolant circuits:

- the first one, including the CFEX is used to deliver the coolant flow to the batteries and creates a closed coolant loop outside the system (ExtCoLoop).
- the second one, including the HFEX, is used to exchange heat with the external environment through a fluid/air heat exchanger (radiator - HEX) mounted inside the unit and creating a closed coolant loop inside the unit (IntCoLoop).

As the CFEX is able only to provide a cold coolant flow, in order to deliver a warm coolant flow to the external users, eBTM 2.0 includes an electric heater (HVH) in the ExtCoLoop.

With reference to the coolant supply at the outlet:

- when eBTM 2.0 delivers a cold fluid flow, provided by the CFEX, the eBTM 2.0 is operating in cooling mode.
- when eBTM 2.0 delivers a warm coolant flow, provided by the electric heater, the eBTM 2.0 is operating in heating mode.

## 7 External interfaces

The customer interfaces are:

- **Fixing brackets:** 4 brackets for fixing the unit are installed on the sides. The fixing brackets are installed by default on the lateral side of the unit. The fixing brackets can be mounted, as an optional, on the longitudinal side sides of the unit. If the latest option is chosen, the fixing bracket pointed by the arrow in Fig. 3 (P/N 6247013) must be changed with a different one (P/N 6247012). The additional bracket is included in the unit.
- **Lifting Points:** 4 lifting points are placed on the upper frame of the unit. Use 4 eyebolts with a M8 screws.
- **Expansion tank caps:** The caps of the expansion tanks should be accessible for maintenance tasks on the fluid circuits. The caps incorporate an overpressure valve opening at 1 bar relative pressure.

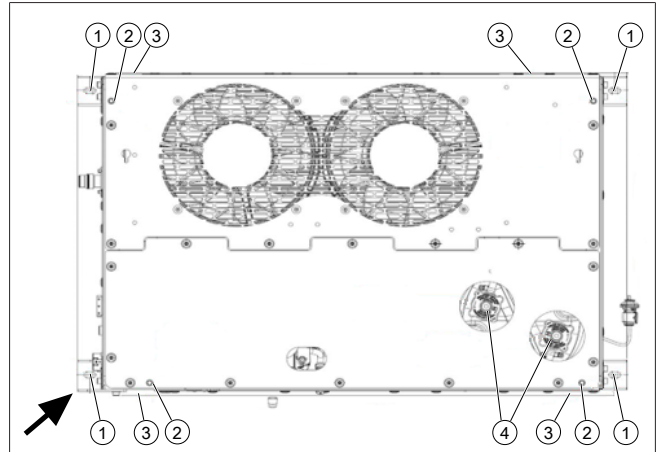

Fig. 3 eBTM 2.0 Front view

1	Fixing brackets on the lateral side	2	Lifting points
3	Fixing brackets on the longitudinal side	4	Expansion tank caps

- **Air openings:** The installation must be designed so that the air openings are not obstructed (shown in Fig. 4).

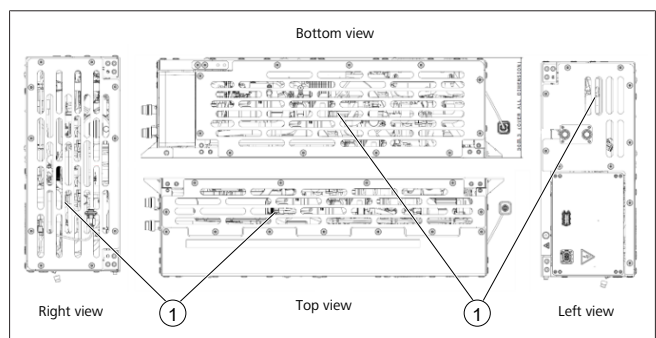

Fig. 4 eBTM 2.0 Side views

1	Air openings
---	--------------

- **High-voltage connection:** The high-voltage interfaces for the 2 different versions of the unit are the following.
  - 400 VDC: max current 20 A (limited by software). HV Customer side: ELP2A0210 + 2x4 mm<sup>2</sup> shielded cable.
  - 800 VDC: max current 20 A (limited by software). HV Customer side: ELP2Y0210 + 2x4 mm<sup>2</sup> shielded cable.

The connectors share the same pin diagram reported in Table 4 on page 7.

- **Low-voltage connection:** 12 Vdc/5 A or 24 Vdc/2,5 A (only for electronics), including interlock and CAN pins.

- LV Customer side: Connector P/N: 211PC249S0053
- Pins P/N:
  - APTIV 211CC2S1160P (0,35-0,75 mm<sup>2</sup>; 1.5x0.8)
  - APTIV 211CC2S2160P (1-2 mm<sup>2</sup>; 1.5x0.8)
  - APTIV 211CC3S1120 (0,35-0,75 mm<sup>2</sup>; 2.8x0.8)
  - APTIV 211CC3S2120 (1-2,5 mm<sup>2</sup>; 2.8x0.8)

- **Equipotential bonding connection:** M6 – 6mm<sup>2</sup> section cable.



Fig. 5 eBTM 2.0 Electrical connections

1	High-voltage connection	2	Equipotential bonding connection
3	Low-voltage connection		

Pin ID	Description
1	HV+
2	HV-
A	Interlock jumper
B	Interlock jumper

Table 4: HV connection pin diagram

Pin ID	Description
A1	KL30 (12V)
A4	WTT/LIN4 (Diagnostic)
A6	Interlock IN
A7	Interlock OUT
A8	KL30 (24V)
B1	GND
B6	CAN2-L (Diagnostic)
B7	CAN2-H (Diagnostic)
C3	CAN3-L (Vehicle communication interface)
C4	CAN3-H (Vehicle communication interface)

Table 5: LV connection pin diagram

- eBTM 2.0 **coolant interface - return:** circuit fitting NORMAQUICK PS3 NW20.
- eBTM 2.0 **coolant interface - delivery:** circuit fitting NORMAQUICK PS3 NW20.

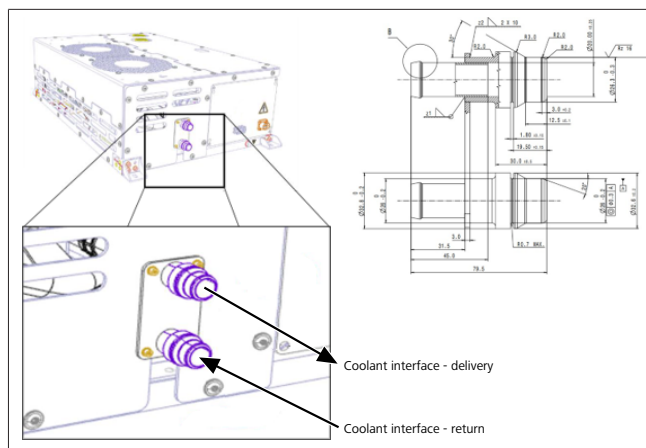

Fig. 6 eBTM 2.0 Coolant interfaces

- **Internal circuit - Fluid purging valves:** two venting valves are located directly on the quick disconnects to the radiator (shown in Fig. 7 and Fig. 8), another metal valve is located on the piping to the evaporator (shown in Fig. 9). Ensure that they are fully closed again after the filling and bleeding procedure.
- **External circuit - Fluid purging valves:** two external circuits venting valves are installed under the covers nearby the evaporators (shown in Fig. 9). Open them only during the coolant filling procedure.



Fig. 7 eBTM 2.0 fluid purging valve at the outlet of the radiator

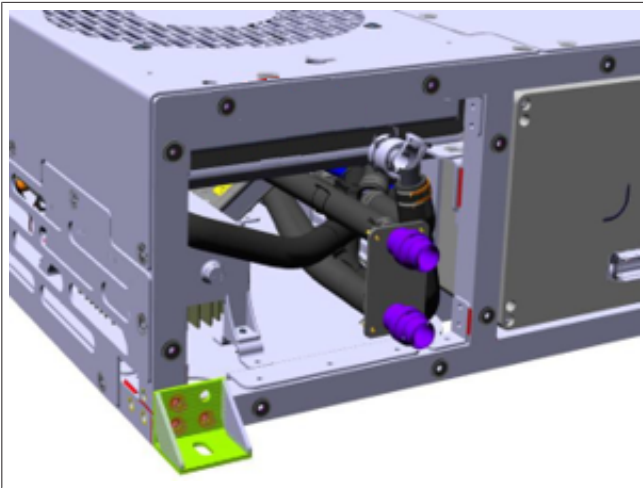

Fig. 8 eBTM 2.0 fluid purging valve at the inlet of the radiator

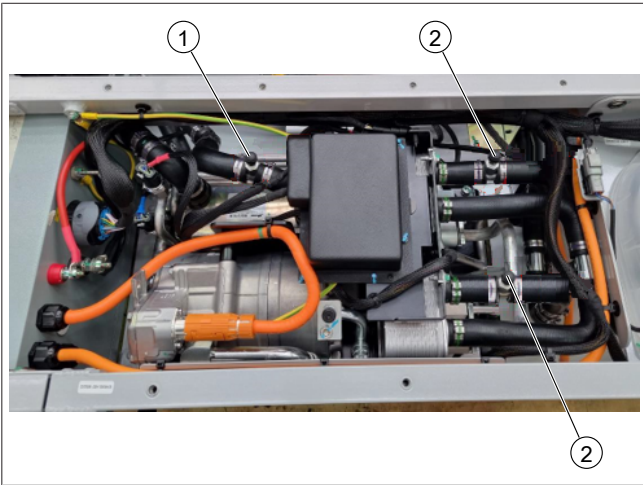

Fig. 9 eBTM 2.0 fluid purging valve

1 Internal circuit fluid purging valve	2 External circuit fluid purging valves
--	---

- **Low-pressure refrigerant charging point:** below the cover.
- **High-pressure refrigerant charge point:** below the cover.

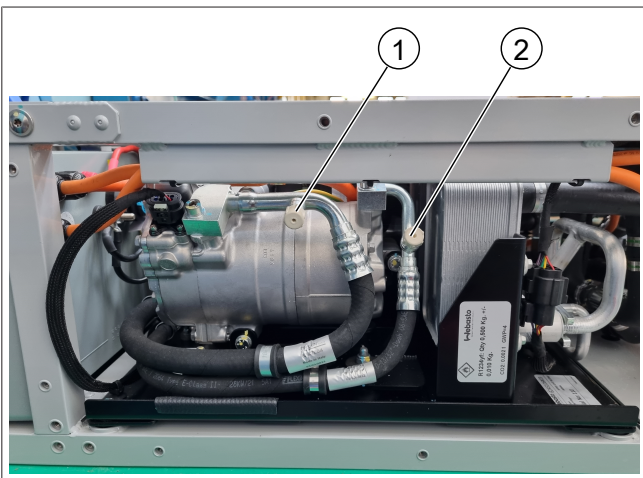

Fig. 10 eBTM 2.0 coolant charging points

1 Low-pressure coolant charging point	2 High-pressure coolant charging point
---------------------------------------	--

## 8 Installation procedure

### 8.1 Installation Recommendations

- Analyse the coolant connections between the eBTM 2.0 and the batteries in use in the vehicle configuration.
- The circuit must be balanced to each battery with the same flow.
- If necessary, use a water tank and a purge valve on the external eBTM 2.0 coolant circuit.
- Unlike a conventional sealed pump, the eBTM 2.0 coolant pump can withstand limited dry run operation. Therefore Webasto recommends avoiding using the eBTM 2.0 internal coolant pump to fill or bleed the internal circuit as this can damage the pump.
- Make sure that the system is constructed in such a way that the coolant level of the external circuit is always **the highest point** in the system.
- Make sure that the eBTM 2.0 is installed horizontally.
- The eBTM 2.0 is delivered with the internal circuit prefilled with water/glycol. After mechanical connection to the batteries, follow the filling and purging procedure of the external circuit.
- When the purge valves are open, those doing the work must protect themselves from water/glycol leakages.
- For the installation and lifting of the unit, use the 4 lifting points marked "2" in Fig. 3.

### 8.2 Planning the installation

#### 8.2.1 Positioning the eBTM

To ensure proper operation of the fans and the radiator, the eBTM 2.0 must be installed far enough away from walls or other obstructions. Insufficient clearance prevents the radiator from dissipating enough heat to the environment in cooling mode. In consequences this degrades the performance of the unit.

Any installation of the eBTM 2.0 shall ensure that the additional pressure loss on the radiator air flow does not exceed 47 Pa @3300 m<sup>3</sup>/h. A test showing an airflow of 3300 m<sup>3</sup>/h or more on the installed eBTM 2.0 with the radiator fans running at maximum speed, is an appropriate means to confirm cooling performance of the application.



#### CAUTION

Install the product in an area difficult to reach by the passengers (roof, under the vehicle or technical compartment).

#### 8.2.2 Battery Circuit Design

The eBTM 2.0 is equipped with two coolant pumps. The first one is integrated in the internal circuit, the second one is integrated in the external circuit and provides coolant flow to the batteries.



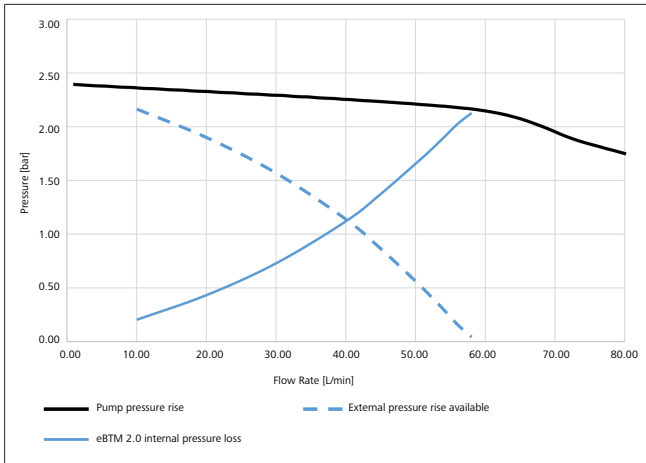

Fig. 11 Available pressure at the supply line of the eBTM 2.0 400 V

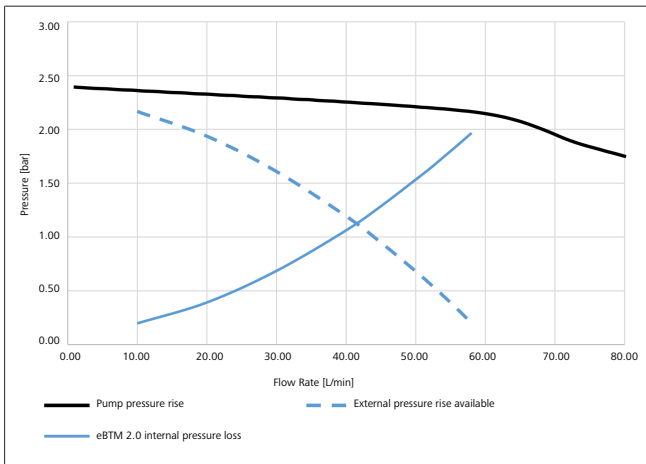

Fig. 12 Available pressure at the supply line of the eBTM 2.0 800 V

The available pressure from the eBTM 2.0 400 V and 800 V with a flow rate respectively of 52 L/min and 54 L/min is 0.5 bar. When designing the coolant system between the batteries and the eBTM 2.0 it is necessary to keep the total pressure losses below the dashed curve shown in Fig. 11 and Fig. 12, depending on the flow rate that must be delivered to the batteries.

Webasto suggests using a manifold, located as close as possible to the eBTM 2.0, to divide the coolant flowing to the batteries and to reduce the pressure losses in the circuit. In order to create a homogeneous flow to each battery, a balanced coolant circuit is recommended.

An example layout providing evenly distributed flow across all Battery Packs, while using simple T-shaped manifolds and varied conduction diameters for trim, is provided with Fig. 13.

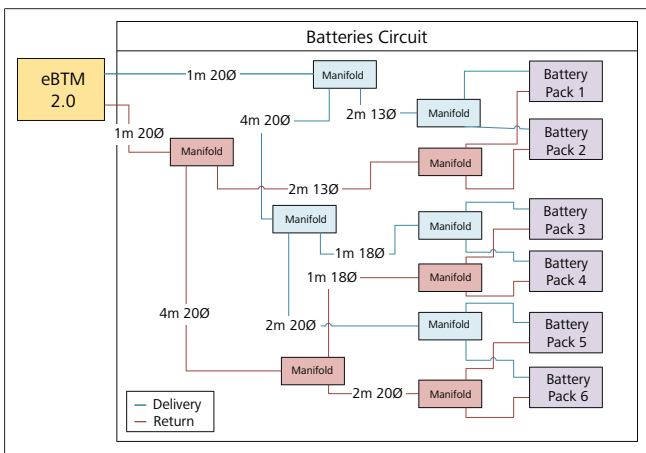

Fig. 13 Example layout of the external coolant circuit

### 8.2.3 Tilt Allowed

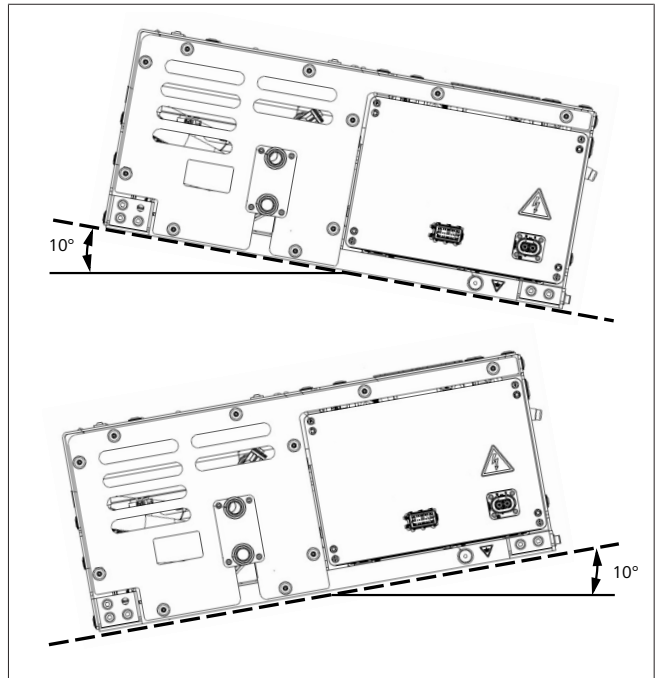

Fig. 14 Tilt allowed

The eBTM 2.0 must be mounted horizontally. A longitudinal installation angle is not permitted. In the lateral direction, a maximum tilt of 10 degrees is allowed, as shown in Fig. 14.

## 8.3 Installation Instructions

### 8.3.1 Mechanical installation



Fig. 15 Removing covers

The integrator is responsible for securing the eBTM 2.0 onto the vehicle.



#### CAUTION

The positions of the mounting bracket strictly must comply with one of the two provided patterns (longitudinal, lateral).

The design of this connection must correspond to the operating loads applicable to the respective application of the eBTM 2.0. To physically install the system:

1. Remove the covers on the tanks, but do **not** remove the cover supporting the fans.
2. Determine the position of the installation brackets.
3. Lift the eBTM 2.0 with a bridge crane utilizing the 4 lifting points shown in Fig. 3. Using a rigid tool avoids damage to the frame.
4. Make sure that the entire surface of the fixing brackets is in contact with the vehicle frame.

5. Fix the eBTM 2.0 using M10 screws, and washers with a minimum outer diameter of 30 mm and minimum thickness 3 mm.
6. Secure the eBTM 2.0 with a torque.
7. The recommended class and torque are respectively 8.8 and 45 Nm.

**CAUTION**

It is not allowed to step on the eBTM 2.0. Stepping on the unit may cause damage the covers, the frame and the internal components.

**CAUTION**

Protect the unit against mechanical stress (e.g. dropping, impacts or knocks).  
Do not place heavy objects on top of the unit.  
Use Safety Gloves.  
Do not stand under the eBTM 2.0 unit.

**8.3.2 Coolant connections**

The eBTM 2.0 must be connected to the coolant circuit of the batteries by using flexible hoses. Coolant connection interfaces must be connected respectively to the inlet, and the outlet of the external cooling circuit (shown in Fig. 6). You must use hoses with a connection compatible with 'NORMAQUICK PS3 NW20' quick connectors.

**NOTE**

The quick disconnects on the coolant interfaces of the eBTM 2.0 indicate correct installation with an audible click and the spring visibly located in the groove of the male part of the eBTM 2.0.

**8.3.3 Electrical connection****WARNING**

To avoid danger of electric shock, **first** install the potential equalization (PE) cables between the eBTM 2.0 and ground properly, **next**, connect the LV- and HV-connectors to the eBTM 2.0.

1. Connect the potential equalization wire from the vehicle to the eBTM 2.0 shown in Fig. 5.
2. Tighten the M6 screw with a torque of 8 Nm.
3. Make sure that the cable has a minimum cross section of 6 mm<sup>2</sup> and is as short as possible.
4. Connect the HV, LV cables respectively to the connectors shown in Fig. 5.

**WARNING**

The resistance of the potential equalization path between the eBTM 2.0 and the vehicle must not exceed 40 mOhm over the lifetime of the system.

**WARNING**

Supplying high voltage to the eBTM 2.0 with the wrong polarity will damage the unit. The eBTM 2.0 cannot handle incorrect HV polarity.

**WARNING**

The system does not control the HV inrush current of the device. For the protection of the HV components, the eBTM 2.0 must be pre-charged at start-up. Because the eBTM 2.0 has no inrush current limitation, the vehicle manufacturer must supply this. The Cx-capacitance (between HPS+ and HPS-) is specified in Table 3 on page 5.

**8.4 Filling circuits****8.4.1 Filling the refrigerant gas circuit**

This chapter describes the filling procedure of the refrigerant gas circuit. The following eBTM 2.0 units are delivered without refrigerant gas: 6247243A / 6247710A

The eBTM 2.0 refrigerant gas charge should be filled in these eBTM 2.0 units before operation.

**WARNING**

Charging the eBTM 2.0 refrigerant gas circuit shall be accomplished by trained and, where legally required, certified technicians only.

**Requirements for the filling process:**

- a 4-way manifold gauge set,
- Flexible hoses,
- a vacuum pump,
- an R1234yf refrigerant cylinder.

**NOTE**

The electric compressor is filled to the line with 120 cc of SP-A2 oil. The compressor has an integrated oil separator, meaning that 50% of the oil remains in the compressor, and 50% will go into the system. When you charge the eBTM 2.0 for the first time, no oil has to be added.

**NOTE**

If an automatic refrigerant gas service system is used, charge the system with 500 g R1234yf. Proceed according to the instructions of the automatic service system.

**To fill the refrigerant gas circuit:**

1. Connect the low-pressure gas charging port (shown in Fig. 10) to the low-side connection of the 4-way manifold gauge set by using a flexible hose.
2. Connect the high-pressure gas charging port (shown in Fig. 10) to the high-side connection of the 4-way manifold gauge set by using a flexible hose.
3. Connect the vacuum pump to the manifold gauge set.
4. Open both valves of the 4-way manifold and turn on the vacuum pump.
5. Vacuum the refrigerant gas circuit.
6. Keep the vacuum pump turned on for 20 minutes to clear any remaining humidity trapped inside the refrigerant gas circuit.
7. Close the valves and turn off the vacuum pump.
8. Leave the circuit under vacuum for 20 minutes. If the pressure increase is less than 10% after 20 minutes, then proceed with the following step(s). Otherwise check for possible leakages or contact the supplier.
9. Connect the manifold gauge set to the pneumatic pump and to a R1234yf refrigerant cylinder.
10. Open ONLY the high-pressure valve of the manifold.
11. Fill the system with 500 g of refrigerant gas.
12. Close the high-pressure valve of the manifold.
13. Remove the flexible hoses.
14. Disconnect the pneumatic pump.
15. Fill in the label (shown in Fig. 16) with the amount of refrigerant gas used to fill the system and attached on the eBTM 2.0 heat pump unit.

<p><b>BG</b> Съдържа флуорсъдържащи парникови газове.</p> <p><b>CZ</b> Obsahuje fluorované skleníkové plyny.</p> <p><b>DA</b> Indeholder fluorholdige drivhusgasser.</p> <p><b>DE</b> Enthält fluorierte Treibhausgase.</p> <p><b>EL</b> Περιέχει φθοριούχα αέρια του θερμοκηπίου.</p> <p><b>EN</b> Contains fluorinated greenhouse gases.</p> <p><b>ES</b> Contiene gases fluorados de efecto invernadero.</p> <p><b>ET</b> Sisaldab fluoritud kasvuhoonegaase.</p> <p><b>FI</b> Sisältää fluorattuja kasvihuonekaasuja.</p> <p><b>FR</b> Contient des gaz à effet de serre fluorés.</p> <p><b>HR</b> Sadržava fluorirane stakleničke plinove.</p> <p><b>HU</b> Fluortartalmú üvegházhatású gázokat tartalmaz.</p>	<p><b>IT</b> Contiene gas fluorurati a effetto serra.</p> <p><b>LT</b> Sudėtyje yra fluorintų šiltnamio efektą sukeliančių dujų.</p> <p><b>LV</b> Satur fluorētās siltumnīcefekta gāzes.</p> <p><b>MT</b> Fih gassijiet fluorurati b'effett ta' serra.</p> <p><b>NL</b> Bevat gefluoreerde broeikasgassen.</p> <p><b>PL</b> Zawiera fluorowane gazy cieplarniane.</p> <p><b>PT</b> Contém gases fluorados com efeito de estufa.</p> <p><b>RO</b> Conține gaze fluorurate cu efect de seră.</p> <p><b>SK</b> Obsahuje fluorované skleníkové plyny.</p> <p><b>SL</b> Vsebuje fluorirane toplogredne pline.</p> <p><b>SV</b> Innehåller fluorerade växthusgasar.</p>	<p>P/N XXXXX</p>
---	---	------------------

**HFO – R1234yf**  kg = CO2  t [GWP=4] 

Fig. 16 Refrigerant gas label

**NOTE**  
 In case the eBTM 2.0 is shipped without refrigerant gas the label will be included in the kit but won't be attached directly on the eBTM 2.0 unit.

**WARNING**  
 You must check for leakages after any work on the refrigerant circuit.

**CAUTION**  
 After any work on the refrigerant circuit, reinstall the protection caps onto the charging valves to protect these against dirt.

8.4.2 Reservoir

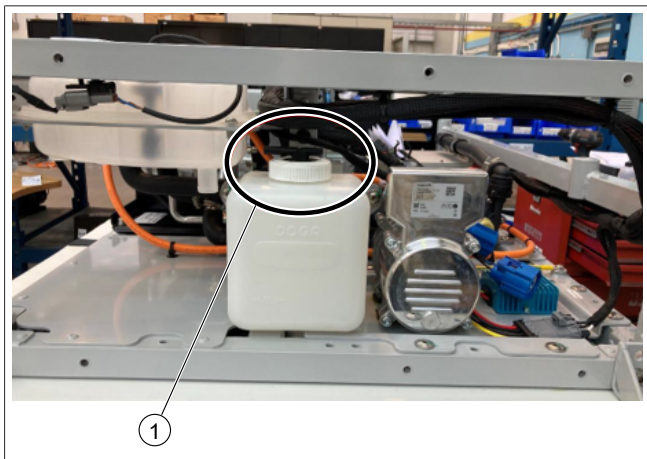

Fig. 17 eBTM 2.0 Additional coolant reservoir

1	Coolant reservoir cap
---	-----------------------

Unscrew the coolant reservoir cap located below the expansion tanks to fill the reservoir with 0.75 litres of coolant.

8.4.3 Filling the coolant circuit

Requirements for the filling process:

- X litres of coolant mixture; 50% Water, 50% Glycol, the quantity of mixture (X) depends on the size of the system (Fig. 19).
- A Venturi nozzle, as shown in Fig. 18.

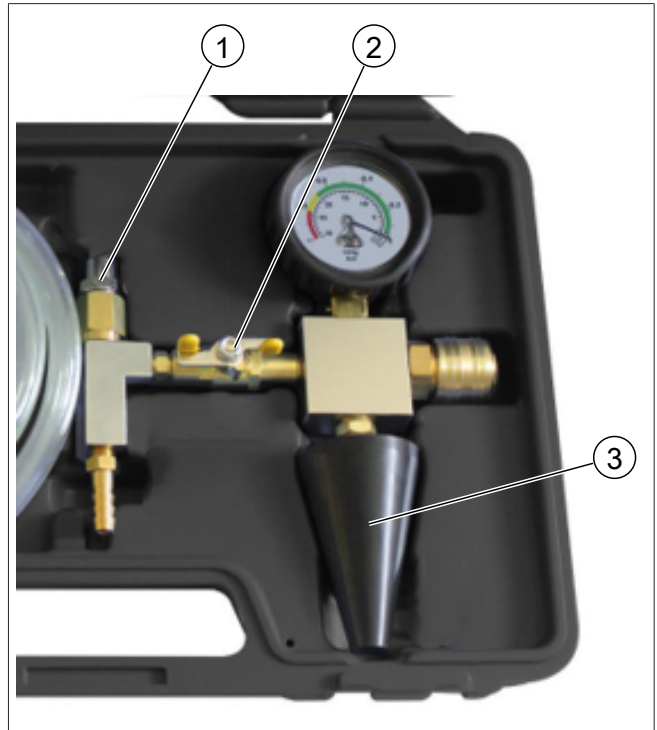

Fig. 18 eBTM 2.0 Venturi vacuum pump

1	Port P1	2	Valve V4
3	Port P2		

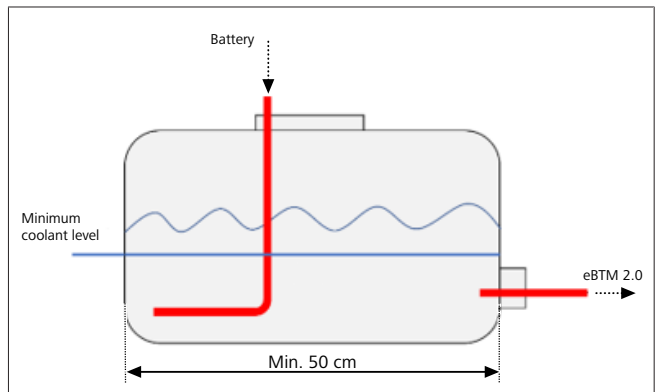

Fig. 19 Tank used for the purging procedure

Planning:

- While designing the coolant system Include 3 manual valves close to the return circuit of the eBTM 2.0 as shown in Fig. 20 (V1, V2 and V3). Those are needed to connect the tank used for the purging procedure.
- If using Webasto batteries make sure that the coolant hoses connected to the batteries heat exchanger are above the level of the plates themselves, this will ensure proper evacuation of the air inside the plates.
- Prepare a tank with the following characteristics:
  - Minimum length of the tank 50 cm
  - 1 opening on top of the tank
  - 1 opening on the bottom of the tank

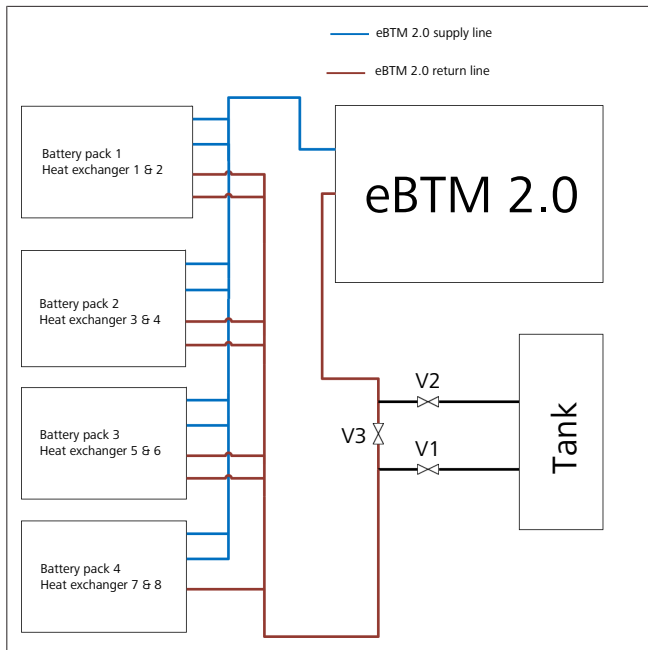

Fig. 20 Possible layout of the coolant system

**Filling and purging procedure:**

1. Close V1, V2 and V3 (shown in Fig. 20).
2. Place the tank close to the return of the eBTM 2.0. In order to properly fill the circuit, place it in a position higher than any other component of the system.
3. Connect one end of a hose to the valve V2 (shown in Fig. 20) and the other end of the hose to the bottom part of the tank (shown in Fig. 19).
4. Connect one end of a hose to the valve V1 (shown in Fig. 20) and insert the other end in the upper opening of the tank (shown in Fig. 19).
5. Make sure that all the purging valves in the system are closed.
6. Fill the tank up to the minimum level, such that the coolant mixture covers entirely the lower opening of the tank.
7. Add in the tank a quantity of coolant needed to fill entirely the system.
8. Connect the port P2 of the vacuum device (shown in Fig. 18) to the cap of the expansion tank of the external coolant loop of the eBTM 2.0 (shown in Fig. 3).
9. Connect the port P1 of the vacuum device to the compressed air source.
10. Open the valve V4.
11. Let the device vacuum the system until a pressure of 0.2 bar is reached, afterward let the valve open for at least 5 minutes.
12. If the system doesn't reach the desired pressure check that all the bleeding valves in the system are properly closed and repeat point 11.
13. Close the valve V4.
14. Let the system rest for 15 minutes. If the pressure doesn't rise more than 0.05 bar move to point 15, otherwise disconnect the vacuum device and check the system for possible leakages and then go back to point 8.
15. Open the valve V2 and let the system suck coolant from the tank for 5 minutes. The return branch from the latest plate to the valve V3 won't be filled and will be full of air.
16. Open the valve V1.
17. Turn on the eBTM 2.0 by setting the activation signal to 1.
18. Set the thermal management request to 1 and the requested coolant temperature set point to 0x7FE. This will activate the external pump at maximum speed.
19. Let the pump run for 5 minutes. During this period most of the air will get out of the system and will be evacuated through the external tank.
20. Turn off the pump by switching the thermal management request to 0 and let the system rest for 1 minute.
21. Repeat the points 18, 19 and 20 at least once so that the coolant enters the tank without bubbles (visual inspection).
22. Close the valves V1 and V2.
23. Disconnect the external tank from the system.
24. Open the valve V3.
25. Set the thermal management request to 1 and the requested coolant temperature set point to 0x7FE. This will activate the external pump at maximum speed. Check that no air is still trapped in the system.
26. Turn off the eBTM 2.0.
27. Disconnect the venturi nozzle.
28. Check that the coolant in the tank is at the correct level as shown in Fig. 21. In case the level dropped refill some coolant from the tank opening.
29. Close the cap of the expansion tank. In case bleeding valves are present in the circuit close them with the appropriate torque.

**CAUTION**  
 After filling the coolant circuits, make sure that the caps are securely closed, and the correct torque has been applied. This is indicated by a mechanical stop, when closing the cap clockwise.  
 Before opening the cap completely, allow the vapors to flow out to lower the pressure. **The vapors can be very hot.**

**NOTE**  
 The evaporator max. height should be at the level of the coolant inside the tank (shown in Fig. 21).

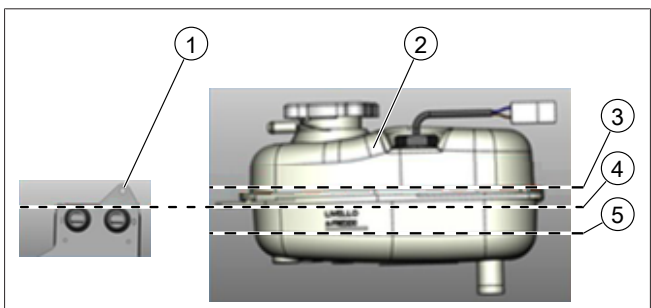

Fig. 21 eBTM 2.0 Coolant level

1	Evaporator	2	Tank
3	Coolant level	4	Max. height of the evaporator
5	Min. coolant line		

## 9 System activation

The activation of the eBTM 2.0 system, the analysis of the status of the internal components and the identification of the working modes according to the external users demands and the external environmental and vehicle conditions are made by the eBTM 2.0 Gateway.

The user must provide an activation signal, which will activate the eBTM 2.0 or keep it in idle mode, and a signal with the requested temperature. If the system is activated and a setpoint temperature is provided, the ECU compares it with the signal from the outlet temperature sensors and decides if the eBTM 2.0 is in heating or in cooling mode.

- When no temperature signal is provided the eBTM 2.0 is in idle mode and all the components are turned off.
- If the eBTM 2.0 is in heating mode, the pumps of the external coolant loop (ExtCoLoop) and the high voltage heater (HVH) are activated. Fig. 22 represents a sketch of the eBTM 2.0 in heating mode.

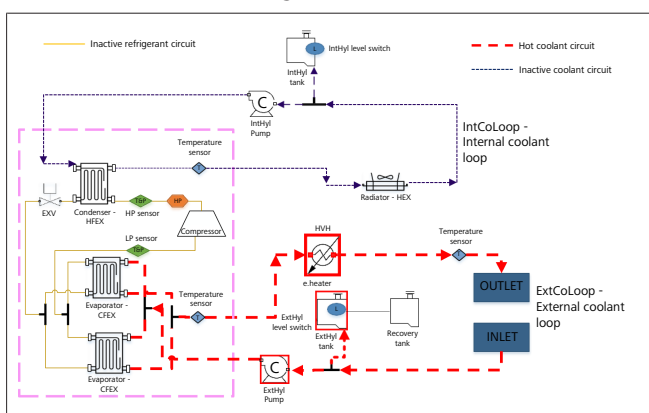

Fig. 22 eBTM 2.0 configuration in heating mode

- If the eBTM 2.0 is in cooling mode, the pumps of the external and internal coolant loop (ExtCoLoop) are activated. Afterward the cooling fans are activated as well as the cooling unit (Webasto heat pump 80). Fig. 23 represents a sketch of the eBTM 2.0 in cooling mode.

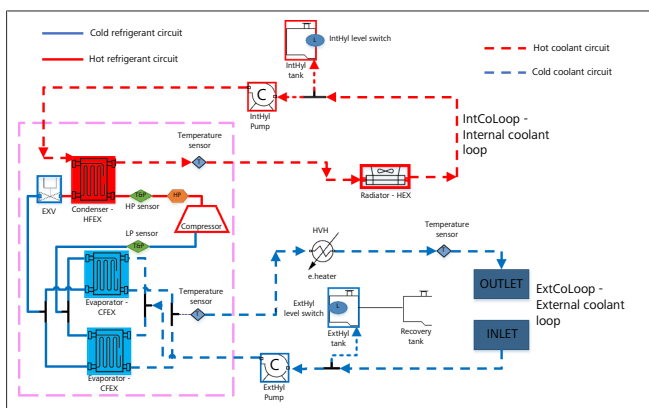

Fig. 23 eBTM 2.0 configuration in cooling mode

To request this documentation in another language, please locate and contact your local Webasto dealer. You can find your nearest dealer at: <https://dealerlocator.webasto.com/en-int>.  
To provide feedback (in English or German), please email: [feedback2tdt@webasto.com](mailto:feedback2tdt@webasto.com)

Europe, Asia Pacific:

Webasto Thermo & Comfort SE  
Postfach 1410  
82199 Gilching  
Germany

Company address:  
Friedrichshafener Str. 9  
82205 Gilching  
Germany

Technical website: <https://dealers.webasto.com>

Only within Germany  
Tel: 0395 5592 444  
Mail: [technikcenter@webasto.com](mailto:technikcenter@webasto.com)

UK only:

Webasto Thermo & Comfort UK Ltd  
Webasto House  
White Rose Way  
Doncaster Carr  
South Yorkshire  
DN4 5JH  
United Kingdom



0000036289A

[www.webasto.com](http://www.webasto.com)

